



**i8-1000  
General Incinerator**

The i8-1000G is our flagship model and boasts a wide array of features - many unique to the i8 range. Developed over the last 3 years the i8-1000G is at the fore-front of combustion technology and offers impressive burn rates and large batch sizes while still achieving some of the lowest emissions in its class.



#### Industry Leading Insulation

Coretex<sup>©</sup> insulation is a specially formulated substrate containing various levels of material that ensure almost all of the heat generated within our incinerators stays inside them - increasing performance and efficiency to another level.



#### Rigid, Long Lasting Construction

All our incinerators are constructed from British made high quality 5mm mild steel plate. They are fully welded for maximum strength by our time-served coded welders. Meaning you get years of trouble-free operation.

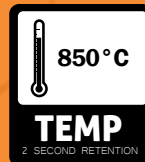

#### Fully Compliant Range

Each of our incinerators has been tested to exacting standards ensuring they meet all required guidelines. They are CE declared to BS E7N4 6-2:1997 (industrial thermo processing equipment – part 2). This machine can reach in excess of 850°C in the secondary chamber and also retains the fumes for the 2 seconds required.



#### Remote Monitoring & Pro-active Analysis (optional extra)

We have developed this control panel to allow trouble-free operation. Data can be fed back to our HQ where our team of engineers monitor and provide advice when required on optimum operation of your incinerator. It also allows us to advise when your service is due to ensure longevity of the unit.



#### Plug and Play CE-7 Control Panel

Completely re-designed and built in-house since 2017. Our control panels now feature:

- Full PLC and touch screen control
- Self-fault diagnostics
- High integrity SIL 3 Safety rated
- Automatic air modulation
- Automatic lid locking
- One button to start system



#### Why is this 3 layer lining so good?

- 25mm insulation block backup layer
- An intermediate insulating layer in a 1260 grade insulation brick (most insulative block available on the market).
- Final layer of 100mm low cement castable
- Fast firing characteristics pre-engineered
- Robust, efficient and long lasting

## Key Parts of our Incinerator

### 5 Zone Thermocouple

Allow independent control of primary and secondary temperatures via the control panel.

### Chimney Stack

Stainless steel stack for longevity. Minimum 5.5m stack height required. Fitted with dispersion cap as standard.

### 7 x Low NOx Burners

These are some of the cleanest, most efficient burners available today. These can be supplied as gas or oil fired.

### Primary chamber

Chamber designed for maximum air flow and circulation which in turn improves efficiency and total burn time.

### Secondary Chamber

Retains and re-burns the exhaust fumes for minimum of 2 seconds at 850°C to meet EU guidelines.

### Safety Features

Kill switches, automatic shutdown, automatic lock clamps all ensure user safety is at the forefront of operation.

### Triple Ash doors

This model now features 'floating' ash doors - Design for better rigidity and can be opened safely.

## How incineration works:

Incineration is a waste treatment process that involves the combustion of organic substances contained in waste materials. Incineration and other high-temperature waste treatment systems are described as "thermal treatment". Incineration of waste materials converts the waste into ash, flue gas and heat. The ash is mostly formed by the inorganic constituents of the waste and may take the form of solid lumps or powder. In some cases, the heat generated by incineration can be used to generate electric power.

## Applications

Our versatile range of general incinerators are designed for a wide range of waste types. This is our flagship model which benefits from a top loading design and features the latest in operator safety and performance. This model can also use our latest control panel technology for remote monitoring.

- Industrial waste applications (including RDF)
- Wood waste
- Mining/exploration/refugee camp waste
- Oil and gas industry waste applications
- Household waste
- Oily filters & Rags
- Plastics
- Some medical waste streams

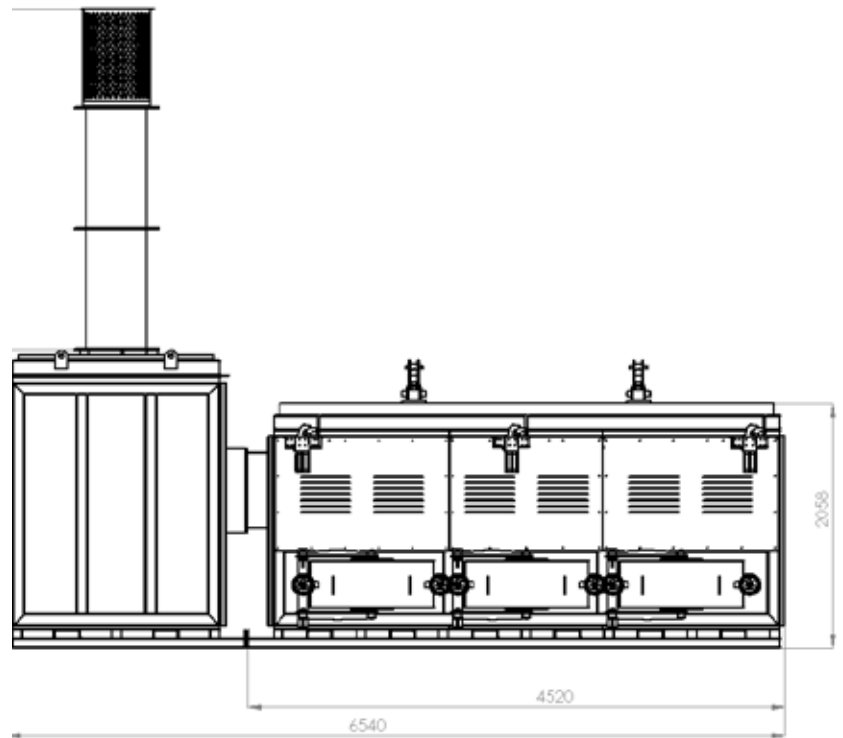
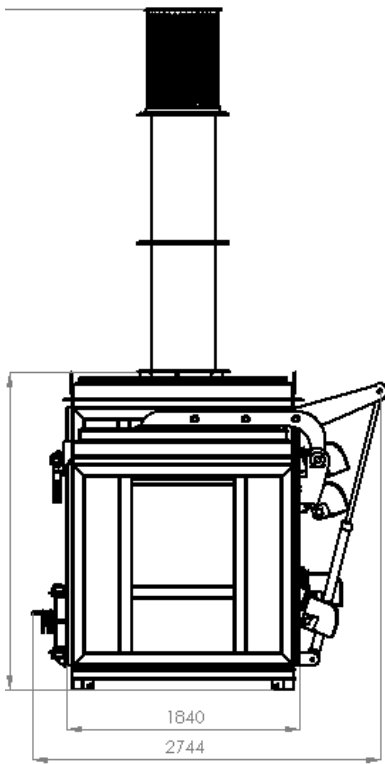

## Technical Specification

\* Dependent on calorific value of waste and local conditions.

Combustion Chamber Volume (m <sup>3</sup> )	8.70m <sup>3</sup>	Average Ash Residue (%)	3%
Metal Thickness	4mm	Thermostatic Device	yes
Burn Rate*	400 - 1000kg per hour*	Shipping Weight (kg)	21500kg
Operational Temperature	850°C	Dimensions (l, w, h)	6.54m x 1.84m x 5.37m
Gas Retention	2 seconds	Door Size (m)	4.0m x 1.50m
Fuel Consumption	40 - 50 ltrs per hour		

**\* PLEASE NOTE:**

Actual burn rates & emissions will depend on a number of factors including waste type, volume of waste, moisture content, fuel used and local environmental conditions.

## Average emissions / EU standards \*

(On basic incinerators with secondary chamber)

Parameter (1/2 hr av)	Limits	Measured
Total dust	30 mg/m <sup>3</sup>	12 mg/m <sup>3</sup>
Sulphur dioxide	200 mg/m <sup>3</sup>	2,4 mg/m <sup>3</sup>
Nitrogen dioxide	400 mg/m <sup>3</sup>	60 mg/m <sup>3</sup>
Carbon monoxide	100 mg/m <sup>3</sup>	78,3 mg/m <sup>3</sup>

\*The above figures are guidelines ONLY.

Actual emissions will depend on a number of factors including waste type, volume of waste, moisture content, fuel used and local environmental conditions.

All our incinerators' chambers are lined with high grade refractory concrete rated to 1600°C. Our secondary chamber technology prevents dioxins from cracking into smaller but more reactive molecules, this is known as de novo formation.

This can be especially apparent in the presence of heavy metals, which can act as a catalyst.

The prevention method can be explained as follows: system design forces the micro particulates to pass through a flame curtain, this burns harmful emissions, gas remnants are then retained in the secondary chamber, through thermal decomposition, and complex, controlled air distribution to ensure a clean odourless emission.

# Site Preparation

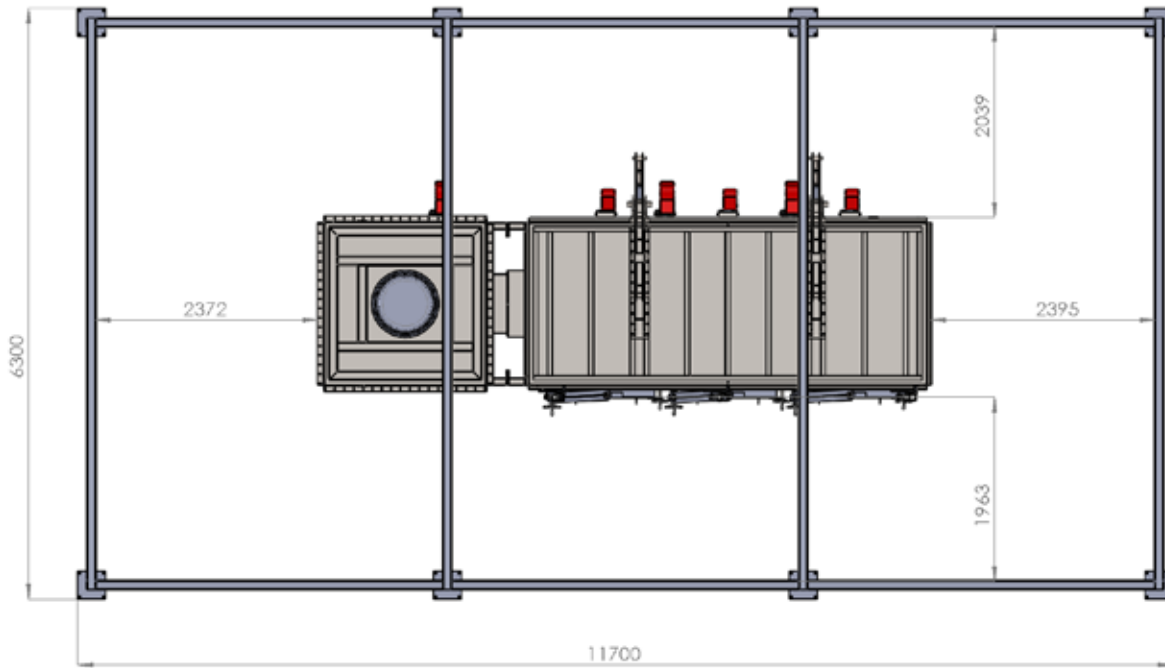

## Sheltered

Ideal weather protection for equipment and operator. Our shelters are designed for easy and quick installation on a standard reinforced concrete slab.

Certain regions require some sort of shelter from adverse weather conditions or localised problems. Our products are used in diverse locations from the freezing camps of Antarctica to sweltering temperatures of Sierra Leone.



## Skid-mounted

For larger models skid-mounting is the most feasible and viable option to allow mobility.

The units arrive complete with electrical power generators and fuel supply with further customization available to suit all needs, regardless of local resources available. The system is available in 20ft and 40ft skids, depending on capacity and optional requirements.



## Trailer-mounted

The trailer is rated to carry up to 32000kg, therefore there is plenty of additional space to carry extra items of equipment including generator sets, fuel and any other equipment. Chassis, framework and panels are galvanized for maximum durability.

These trailers have been built to withstand the rigours of the construction industry. The beam axle system features sealed, specialised wheel bearings and powerful auto-reverse brakes and is unequalled for strength and durability.



All containers supplied are ISO 6346 certified, so they can be used for the shipping and housing of incinerators and any other related equipment.

## CE DECLARATION.



### **MACHINE LISTED BELOW HAS BEEN TESTED BY MANUFACTURER IN FACTORY BEFORE DISPATCH**

PRODUCTION DATE: 2018  
CONFORMS TO ALL SAFETY NORMS WHEN USED ACCORDINGLY  
"CE DECLARATION OF CONFORMITY"  
"CE DECLARATION DE CONFORMITE"  
"CE DECLARACION OF CONFORMIDAD"  
"CE ATTESTATO DI CONFORMITA"  
"EG- KONFORM IT A TSEKRLARUNG"

**INCINER8 LTD, UNIT 2, CANNING ROAD INDUSTRIAL ESTATE, CANNING ROAD,  
SOUTHPORT PR9 7SN, UNITED KINGDOM**

Has declared that the machinery described:  
Declares que les machines descrites:  
Declaramos que la maquinaria descrita:  
Dichiara che la macchina di seguito descrito:  
Bestatigt daB die hierunter beschreibt Maschine:  
Model (Modele; Modelo; Modello; Modell) :

## CE INCINERATOR I8-1000 C/W Eco Flam Burners

Serial Number (Numero de Serie; Numero de Fabricacion; Numero di Serie; Registriernummer) : INCIN8(ABP)845  
Conforms to the following directives: Est conforme aux Directives suivantes: Es conforme a las Directivas siguientes:  
E conforme alle disposizioni contenute nelle seguenti direttive: Ist gemaB folgenden Richtlinien hergestellt worden:

### **1.BS EN 746-2:1997**

(industrial thermoprocessing equipment – part 2. Safety requirements for combustion and handling systems)

### **2.Low Voltage Directive 73/23/EEC**

Directive Basse Tension  
Directive Baja Tension  
Direttiva Sulla Bassa Tensione  
Niedrige Sapnnung – Richtlinie Diretivas

### **3.EMC Compatibility Regulation 89/336/EEC**

Directive CEM  
Directiva CEM  
Direttiva Compatibilita Elettromagnetica  
Elektromanetische Vereinbarkeit – Richtlinie Directive EMC

### **4.Machinery Directive 2006/42/EC (including amendment)**

Directive Securite Machines  
Directiva Seguridad Maquinas  
Direttiva Macchine  
Maschinen – Richtlinie Directiva De Maquinario

### **5. (EC) No 1005/2009 on substances that deplete the ozone layer**



 **INCINER8**

[www.inciner8.com](http://www.inciner8.com)

INCINER8 Ltd is one of the largest suppliers of incinerators throughout the world. Manufacturing in a factory in Southport and shipping out products all over the world through our dedicated sales team & Global Dealership Network.

An experienced team of researchers, designers and engineers have made INCINER8 an innovator in the waste incinerator sector, achieving two Queens Awards and many regional business awards.

Our hand engineered machines can process municipal, medical and animal waste streams, providing the best solutions to waste problems around the world.



Certificate No. 6596



## Speak to the Experts

Our technical sales team are always on hand to answer any questions you may have.

Call **+44 1704 884020** or email [sales@inciner8.com](mailto:sales@inciner8.com)